

WING ELEVATION

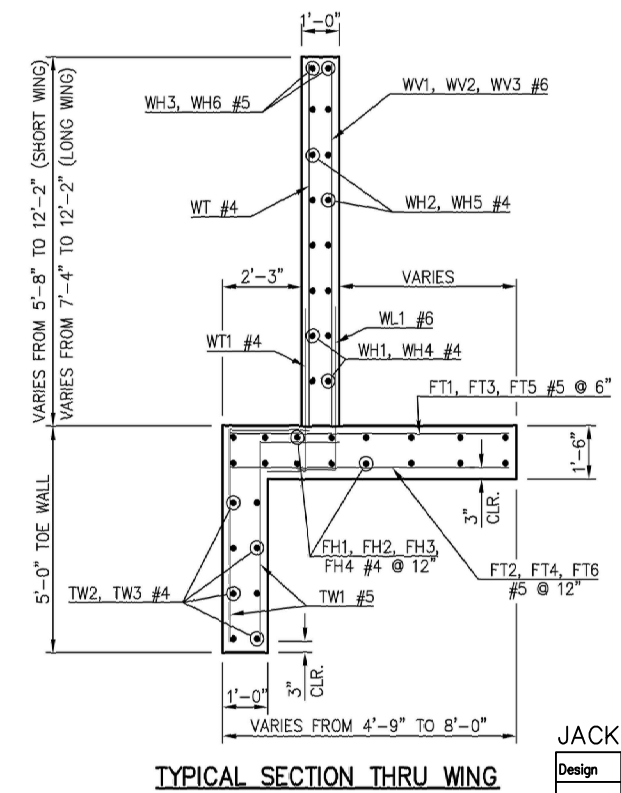
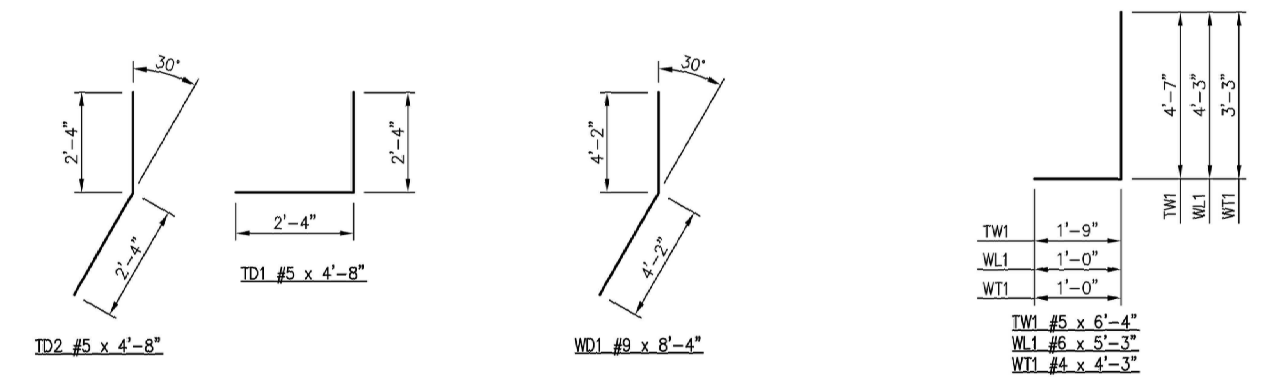

TYPICAL SECTION THRU WING

WINGWALL BAR LIST				
LONG AND SHORT WING INCLUDED				
MARK	SIZE	QTY.	FORM	LENGTH
				VARIANCE
FH1	#4	10	STR.	22'-9"
FH2	#4	8	STR.	15'-1" AVG.
FH3	#4	10	STR.	38'-7"
FH4	#4	8	STR.	27'-0" AVG.
FT1	#5	32	STR.	7'-8"
FT2	#5	17	STR.	7'-8"
FT3	#5	29	STR.	6'-0 1/2" AVG.
FT4	#5	15	STR.	6'-0 1/2" AVG.
FT5	#5	43	STR.	6'-0 1/2" AVG.
FT6	#5	22	STR.	6'-0 1/2" AVG.
TD1	#5	8	BNT.	4'-8"
TD2	#5	8	BNT.	4'-8"
TW1	#5	120	BNT.	6'-4"
TW2	#4	8	STR.	21'-6"
TW3	#4	8	STR.	37'-0"
WD1	#9	44	BNT.	8'-4"
WH1	#4	10	STR.	20'-2"
WH2	#4	12	STR.	11'-3" AVG.
WH3	#5	2	STR.	20'-5"
WH4	#4	14	STR.	30'-2"
WH5	#4	8	STR.	16'-1" AVG.
WH6	#5	2	STR.	29'-9"
WL1	#6	102	BNT.	5'-3"
WT1	#4	55	BNT.	4'-3"
WT2	#4	5	STR.	12'-0"
WT3	#4	20	STR.	8'-8" AVG.
WT4	#4	30	STR.	9'-6" AVG.
WV1	#6	4	STR.	12'-0"
WV2	#6	20	STR.	8'-8" AVG.
WV3	#6	30	STR.	9'-6" AVG.

- ① 2 SETS OF 4 BARS
- ② 2 SETS OF 6 BARS



JACKSON COUNTY TRIBUTARY OF BITTER CREEK
 Design J.S.N. 8/16
 Drawn T.C.B. 12/16
 Checked M.E.C.
 Approved J.S.N.
 Consultant CED #7
 RCB CULVERTS—WING DETAILS
 10'-0" HEIGHT—30"
 (SHEET NO. 2 OF 2)
 STATE/JOB No. 32622(04) Sheet No. 14